

# Fredrick Hisbrook

Multimedia Specialist



512-963-9300  
fredrickhisbrook@gmail.com

Portfolio: [www.hisbrook.com](http://www.hisbrook.com)  
Secret Clearance / Date Granted: 10/5/2020

I am a results-driven Multimedia Specialist with a proven track record of delivering high-quality visual products that meet client expectations and business goals. By leveraging my extensive experience in multimedia, I ensure that every project not only meets the immediate needs of stakeholders but also aligns with broader organizational objectives. I excel at communicating the vision and goals to all stakeholders, ensuring alignment and clarity throughout the project lifecycle.

My expertise spans creating impactful graphics for technical manuals, presentations, flow charts, schematics, and signage, all designed to communicate complex ideas effectively. Additionally, I have experience in developing Computer-Based Training (CBT) graphics and multimedia content to enhance training and development. I thrive in collaborative environments, where innovation and cross-functional teamwork drive success and deliver exceptional results.

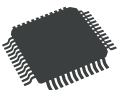

# My Background

## • Training & Development - Semiconductor:

I have experience in supporting training and development through various methods, including mentoring new hires and coaching them on production training processes and certification. I have worked closely with Subject Matter Experts (SMEs) and engineering teams to capture proper training techniques and safety procedures, ensuring accuracy in training documentation. This involved taking instructional photos of the processes and safety preparation, which were integrated into technical manuals and training materials. My expertise extends to creating technical illustrations and developing interactive computer-based training programs. Additionally, I have produced training videos for orientations to enhance learning and ensure compliance with safety protocols. Tools used: Illustrator, Photoshop, Corel, Macromedia Director, Nikon Cameras, Sony Handicam Video Cameras.

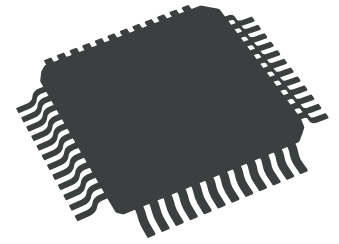

## • Technical Illustration for Technical Publication

I have experience creating isometric illustrations from CAD models to support technical publications in the aerospace, land and armament, and semiconductor industries. I collaborate closely with Technical Writers and Subject Matter Experts (SMEs) to ensure that the storytelling aspect of the content in storyboards is accurately represented and aligned with the intended messaging. This includes producing detailed illustrations for manuals and training materials, while interpreting engineering schematic drawings and technical documents to create precise vector isometric images. Additionally, I am skilled in developing Block and Detail schematic layouts, enforcing standards by adhering to ANSI Y32 grid standards and S1000D layout requirements for data modules. Tools used: ISODraw CADprocess, SAP 3D Visual Enterprise, SolidWorks 2019, Illustrator, Photoshop, and Acrobat.

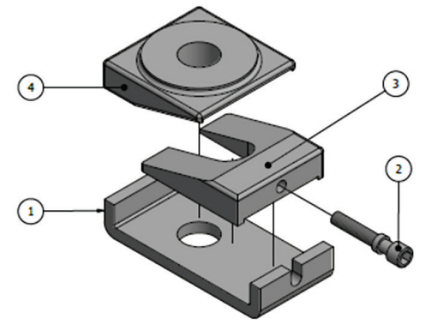

## • Marketing and Graphic Design:

I have extensive experience in integrating page layout and typography with custom vector designs and photographic illustrations. My work includes strategic branding and the execution of creative campaigns for POS marketing, signage advertisement, and internal and external marketing advertisements. I regularly visited local businesses and universities to gather information and photographs for their marketing needs. Based on the data collected, I created tailored marketing materials such as posters, banners, and pop-up displays. Once proofs were completed, I presented the designs to clients for approval through PDF or printed examples, ensuring their feedback was incorporated before final production of the signage.



Drawing from my background in the sign industry and large-format printing, I utilized my skills to operate large-format printers, laminators, and vinyl cutter machines for the production of custom signage. When necessary, I also outsourced signage production to meet clients' deadlines and specific printing needs. My experience includes creating banners, displays, decals, car wraps, and outdoor signage on a variety of substrates, ensuring that all graphic and printing requirements were met on time.

Tools used: Illustrator, Photoshop, InDesign, Corel, Acrobat, Photography, Roland, Mutoh, Kodak, HP Printers, Laminator, Vinyl Cutters, Rip software



## • Web Content Management and CBT Development

My experience in web content management and CBT development enables me to integrate my graphic design expertise with tools like WordPress and Dreamweaver. I focus on creating visually compelling UI elements, including page templates, buttons, menus, forms, and icons, that improve both user experience and engagement. Whether managing web content or designing CBT materials, I apply comprehensive Visual Communication principles to ensure that every aspect of the interface enhances functionality and aesthetics, resulting in a seamless user interaction.



# Technical Skills / Education

## Design Software

Photoshop ★★★★★ Dreamweaver ★★★★★  
Illustrator ★★★★★ Flash ★★★★★  
CorelDraw ★★★★★ Final Cut Pro 6 ★★★★★  
Authorware ★★★★★ Premier ★★★★★  
InDesign ★★★★★ Audition ★★★★★

## Microsoft

Word ★★★★★  
PowerPoint ★★★★★  
Acrobat ★★★★★  
Excel ★★★★★  
Visio ★★★★★

## Engineering Software

ISODraw IML Macros ★★★★★  
ISODraw CadProcess ★★★★★  
Visual Enterprise 9.0 RH ★★★★★  
Solid works 2019 ★★★★★  
Team Center "CPLM" ★★★★★  
Eagle Publishing System ★★★★★

## Printing Equipment

Roland Printer ★★★★★  
Mutoh Printer ★★★★★  
HP 5000 Printer ★★★★★  
Kodak Printer ★★★★★  
Orca Laminator ★★★★★  
Summa Cutter ★★★★★

High School Graduate Johnston High  
School 1985 Austin, Texas  
Major in Commercial Art two years

Consulting Solutions:  
Multimedia Specialist – Certificate  
August 19th, 2013.

# Work Experience

## Northrop Grumman – Defense Systems – Melbourne, Florida

March 19, 2020 – Current

### Sr. Principal Graphic Artist / Descriptive Lead (IPD, RNI, Descriptive, and Schematic Development)

As an experienced technical illustrator and graphic designer, I have worked with a range of software tools, to create high-quality technical illustrations and visual designs. My skills and responsibilities have included:

- Creating exploded isometric views of CAD images, using Vispro and converting them to SVG files.
- Worked with technical writers, to better understand component breakdowns for technical illustrations and visual clarity.
- Maintaining ISODraw master files, CGM, SVG, JPG files, photos, and 3D CAD model libraries.
- Recreate legacy artwork using ISODraw, Illustrator, Photoshop, and Teamcenter Visual Pro.
- Retouch and manipulating photographic images using Photoshop.
- Maintain and create new ICN number graphics for the technical publication library Eagle Publishing System.
- Meet internal customer graphic design needs and deadlines with a proven ability to lead design teams.
- Create ISODraw macros to streamline production build of new graphic images.
- Developed a new schema standards and rules for blocks and detail schematics and updated libraries, and templates.
- Developed new schematic simulation process using interactive templates with buttons and flow animation.
- Created Isodraw macros for standard templates and rules and to help streamlining the illustration build process.
- Trained other illustrators on graphics standards and software tools.
- Familiar with industry standards such as S1000D, STRIKE STYLE GUIDE, NAVAIR, ANSI Y32.2 IEEE STANDARDS.

## Austin 311 – Austin, TX

Oct 5, 2020– March 10, 2021

### Customer Service Representative

- As a public servant working as a Customer Service Representative, my main responsibility was to assist customers by providing them with accurate and relevant information. To achieve this, I used various internal city websites to gather information on topics such as city agencies, local businesses, and upcoming events. By doing so, I was able to enhance the overall experience and satisfaction of customers who interacted with me.

## Collecting Unemployment – Sierra Vista, AZ

May 8, 2020-Oct 5, 2020

- I was laid off from Northrop Grumman in May 2020 due to restructuring. As a former employee, I was grateful for the company's efforts to assist me and other impacted colleagues in finding other positions within Northrop Grumman. During the layoff, I actively searched for work and collected unemployment benefits while also going through the security clearance process as Northrop Grumman had been helping me with the background check."

As a skilled technical illustrator and graphic designer, I have experience in various aspects of the field. My responsibilities and skills have included:

- Create exploded isometric views of CAD images using Visual Enterprise and converted them to various file formats.
- Worked with technical writer and engineers to better understand component breakdowns for technical illustrations.
- Took photos of systems and components for use in technical manuals.
- Maintained technical illustration master files, photos, and 3D CAD model libraries.
- Recreated legacy artwork using various software tools like ISODraw, Illustrator and Photoshop.
- Retouched and manipulated photographic images to meet specific requirements needs for technical manual.
- Created custom technical manual CD cover designs and poster for external customers.
- Maintained ISODraw master files, CGM, SVG, JPG files, photos, and 3D CAD model libraries.
- Meet internal customer graphic design needs and deadlines with a proven ability to excel in a fast-paced, detail-oriented environment.
- My extensive experience and knowledge of technical illustration and graphic design, along with my ability to collaborate effectively with subject matter experts and technical writers, allows me to be a productive member to the technical publication team.

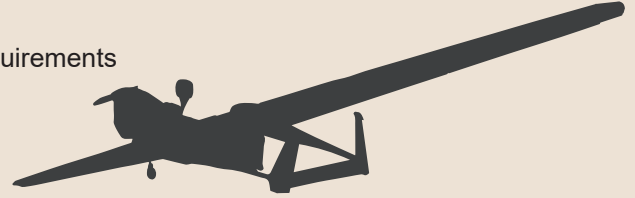

**Aerotek (Contract) with Northrop Grumman - Sierra Vista, AZ**  
**Technical Illustrator**

**July 31, 2017 – July 26, 2019**

As a skilled technical illustrator and graphic designer, I worked as a contractor with Northrop Grumman, utilizing various tools to complete my responsibilities and tasks. Some of my responsibilities and skills during my time at Northrop Grumman included:

- Created exploded isometric views of CAD images using Solidworks or Visual Enterprise and converting them to CGM.
- Worked with SMEs/Engineers to better understand component breakdown for technical illustrations.
- Took photographs of Hunter systems and components for use in technical manuals.
- Maintained ISODraw master files, CGM files, photos, and 3D CAD model libraries.
- Worked with technical writers to ensure technical illustrations are properly illustrated for visual clarity.
- Recreated legacy artwork using ISODraw, Illustrator, Photoshop, SAP 3D Visual Enterprise, Solidworks, or photography.
- Retouched or manipulating photographic images using Photoshop.
- Created custom technical manual CD cover designs for external customers.
- I using PDM Vault, Team-Center, eQUBE to download, maintain, manipulate, and convert CAD files for technical illustrations.
- Maintained and created new TM Numbers and ICN numbers for the technical publication library.
- Demonstrating a proven ability to meet internal customer graphic design needs and deadlines.



**SpeedPro Imaging – Pflugerville, TX**  
**Production Manager / Graphic Designer**

**July 2016-July 2017**

- Conducted one-on-one consultations with potential clients and promoted signage capabilities
- Created graphic designs and marketing advertisement signage for local businesses using software tools such as Photoshop, Illustrator, InDesign, Corel, Acrobat, MS Office, Flexisign, Wasatch, Roland Printer, and Laminator
- Demonstrated expertise in creating banners, signs with substrates, trade show graphics and displays, car wraps, window perfs, and a variety of decal capabilities
- Ran and maintained large format Roland printers and Camm 1 Pro vinyl cutter
- Trained production staff on equipment and production procedures
- Knowledgeable in installing banners, signs, window decals, car decals, and car wraps.





**FARE Driver (Taxi Driver) – Austin, TX**

**June 2016-July 2016**

**UBER Driver (Taxi Driver) – Austin, TX**

**Jan 2016-June 2016**

**Collecting Unemployment – Austin, TX**

**Oct 2015-Jan 2016**

• Actively searching for full time creative position.

**CDI Corporation (Contract) with Applied Materials – Austin, TX**  
**Technical Illustrator for CMP Engineering Group**

**June 22, 2015 – Oct 30, 2015**

During my previous experience Applied Materials, I utilized a range of software tools, including Photoshop, Illustrator, PowerPoint, Excel, and the iOMS-Bill of Materials Database. My responsibilities included:

- Collaborating with SME Engineers to develop accurate Bill of Material parts lists.
- Creating technical illustrations that adhered to BOM callout standards.
- Producing instructional presentations that effectively communicated BOM parts lists using PowerPoint.
- Generated final JPEG images for use in production technical manuals.
- Uploaded SOE Parts List Excel Files and JPEG images into the iOMS database.

**Contract Engineering Services (Contract) with BAE Systems – Sealy, TX**  
**Technical Illustrator III supporting Land & Armaments Division**

**April 2014 – June 19, 2015**

As a contractor with BAE Systems, I utilized a variety of software tools, including ISODraw Cadprocess, Illustrator, Photoshop, and Acrobat, to produce technical publication illustrations. Some of my responsibilities during my contract included:

- Creating and updating technical illustrations for various military vehicles such as the Bradley M88 Recovery Vehicle, A1/A2 Tanks, Panther, and the MMPV vehicle.
- I collaborated with engineers and technical writers to ensure accuracy and clarity of illustrations.
- Adhered to customer specifications and style guidelines for technical publications.
- Conducted quality checks and revisions to ensure high-quality end products.
- Managed and organized digital files and assets for efficient and effective production workflows.

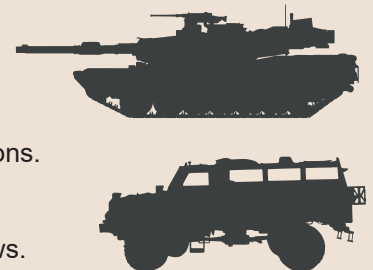

**GCA Services (Temp) with Freescale Semiconductor – Austin, TX**

**Oct 2013 – April 2014**

- As a Moss 11 Metals Production Operator, I worked in the metals department and operated machines that applied a layer of metal onto wafer products. This involved loading the wafer products into the machines, setting up the equipment, monitoring the production process, and ensuring quality control. I have experience in metal coating and plating processes, as well as a strong understanding of machinery and equipment operations within the semiconductor arena.

**Collecting Unemployment – Austin, TX**

**May 2012 – Oct 2013**

- Actively searching for creative position and completed a Multimedia Certificate course

**Info Trust Group – Austin, TX**  
**Senior Technical Illustrator supporting Aerospace and Semiconductor**

March 2006 - May 2012

During my employment with Info Trust Group. I utilized my skills in graphic design and technical illustrations to support our creative and technical documentations group with our semiconductor and aerospace contracts.

- Created exploded isometric views of Cad images that incorporate technical information and customer illustrating standards to support the images.
- Experienced in updating and recreate bitmap images to vector illustrations of mechanical systems, schematics, charts, graphs, and other technical designs.
- Worked as a lead graphics designer and Instructional Photographer and collaboration with multiple subject Matter Experts (SMEs) to create training documentation and photography that support safety, operational procedures, and PM maintenance on a variety of semiconductor and SUNFAB equipment.
- Proficient in restoring, manipulating, and color-correcting photographic images using Photoshop for use in a variety of multimedia programs and other training documentation.
- Maintained photo asset library and digital video, camera, and printing equipment as well as photoshoot scheduling with semiconductor SME, engineers, and management.
- Software used were Isodraw, illustrator, photoshop, final cut pro, and premier.

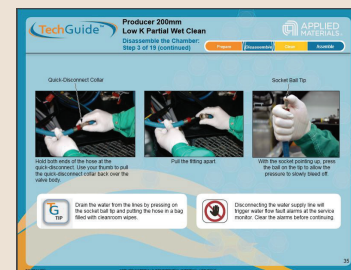

**Pro Graphixs – Austin, TX**  
**Graphic Designer and Printing Specialist**

Jan 2005-March 2006

- Skilled in creating banners, signs with substrates, trade show graphics and displays, car wraps, window perfs, and a variety of decal capabilities to meet customer needs.
- Capable of running and maintaining Large Format Roland Printers, as well as the Camm 1 Pro Vinyl Cutter, to produce high-quality prints and cut vinyl graphics.
- Experienced in training production staff on equipment operation and procedures to ensure efficient and effective production processes.
- Knowledgeable in installing window and car decals, car wraps, lamination, weeding, sign mounting using a laminator, and other installation techniques to ensure accurate and professional results.
- Proficient in using software such as Photoshop, Illustrator, InDesign, Corel, Acrobat, MS Office, Flexisign, Wasatch, and other tools to create graphic designs and marketing advertising signage for local businesses.

**Brown Distributing Company – Austin, TX**  
**Sr. Graphics Technician**

Jan 2002-Jan 2005

- Collaborated closely with internal and external customers to create special themed design POS signage, such as for the University of Texas, Texas State, Round Rock Express, and other local businesses.
- Produced pricing advertisements for product merchandising using graphics design, typography layouts, and print. Created customized product templates that can be used regularly for any business special events, ensuring efficient and effective signage production.
- Served as a lead print specialist on Kodak printers, ensuring high-quality prints and smooth production processes.
- Laminated and mounted signs on coroplast, using professional installation techniques to ensure accurate and professional results.
- Created custom vector images and used Vinyl Cutter.
- Conducted vinyl weeding, taping, and mounting onto various substrates, ensuring accurate and professional results.
- Troubleshoot and repaired solvent printers, copiers, scanners, cutting tables, and software on PC's.
- Updated and revised all graphic library files to ensure accurate and up-to-date design assets.
- Maintained printing inventory and supplies, ensuring that production processes could continue smoothly



- Operated the probe cash box to manage cash transactions and ensure accurate record-keeping.
- Sorted and ran currency through a counter machine to ensure accurate counting and reconciliation of cash.
- Ran coins through a counter to accurately count and manage coin transactions.
- Fulfilled customer orders for bus passes, ensuring that all orders were accurate and processed efficiently.

**HISBROOK GRAPHICS – Austin, TX**  
**Free-lance Designer / Print Broker**

Jan 2000-Jan 2001

- Produced custom graphic designs and marketing advertisement signage for local businesses, ensuring that each design accurately reflected the brand and met the needs of the customer.
- Outsourced all production printing to local businesses, leveraging their expertise and resources to ensure high-quality and efficient production processes.
- Installed signage and decals for customers, ensuring that each installation was accurate, professional, and met the needs of the customer.



**IBT TECHNOLOGIES – Austin, TX**  
**Senior Graphic Designer (Knowledge Advancement System - KAS Specialist)**

Jan 1999-Jan 2000

- Utilized Photoshop, Illustrator, Corel, Acrobat, MS Office, Flash, and Macromedia Authorware to create corporate logos and graphic designs for interactive web-based training programs, ensuring that each design was visually engaging, effective, and met the needs of the customer.
- Created animations, composite designs, and edited sound files to enhance the quality and effectiveness of training programs.
- Managed large-scale graphic promotional projects and remained within budget, demonstrated strong project management skills and attention to detail.
- Demonstrated a proven ability to understand client concerns and meet customer deadlines, ensuring that each project was completed to the satisfaction of the customer.
- Interacted effectively with clients and production personnel, maintaining strong working relationships and



**Manpower – (Contract) with IBM – Austin, TX**  
**Senior Graphic Designer**

Jan 1998-Jan 1999

- Utilized Photoshop, Illustrator, Corel, PPT, MS Office, Dreamweaver, and Freelance Graphics to create high-quality illustrations for Red Book technical manuals, ensuring that each illustration was accurate, effective, and visually appealing.
- Maintained the Admin Center ISO website, ensuring that all content was up to date and accurate, and that the website remained user-friendly and easy to navigate.
- Created corporate logos, flyers, brochures, posters, CD covers, and presentations for IBM internal customers, demonstrating a strong ability to understand client needs and create compelling designs that met their requirements.
- Interacted effectively with clients and production personnel, building strong relationships and collaborating effectively to achieve project goals.
- Coordinated and maintained production projects, ensuring that all work was completed on time, within budget, and to the satisfaction of the customer.
- Trained and mentored graphic designers illustrating software, sharing your expertise and knowledge to help others develop their skills and improve the quality of their work.

**Collecting Unemployment – Austin, TX**  
**Actively searching for work**

**Jan 1997-Jan 1998**

**MOTOROLA – Austin, TX**  
**Developmental Specialist / Instructional Designer / Media Specialist**

**Jan 1987-Jan 1997**

- Provided leadership as a lead instructor and supervisor for new hires and contract employees.
- Collaborated with department heads to evaluate current procedures and determine present and future staff requirements.
- Trained, certified, and maintained all documentation and databases for operators.
- Researched, designed, and implemented staff development programs to improve orientation and operational procedures.
- Produced high-quality videos and photographs for special events.
- Designed graphics for a range of media including newsletters, brochures, technical notes, posters, flyers, manuals, web courses, and training presentations.
- Developed a computer interactive inspection database to streamline processes and increase efficiency.